

Head Office (Australia)
AUTOINGRESS Pty Ltd
17-19, Cronulla Court,
Slacks Creek, QLD-4127

Smart Experience Centre (India)
AUTOINGRESS India Pvt Ltd
"Pettukola Towers", Ground Floor,
190A, Poonamallee High Road,
Kilpauk, Chennai – 600010. India
+91 44 4216 8688 / 73588 51555 / 90253 54812
smart.autoingress@gmail.com www.autoingress.in

Factory Office (India)
AUTOINGRESS India Pvt Ltd
B-4/32, SIDCO Industrial Estate,
Maraimalai Nagar, Chennai – 603209.
+91 44 4865 2151 / 73388 52902 / 73588 51555
sales@autoingress.in www.autoingress.in

Social Media Connect



ISO 9001:2015 CERTIFIED



Your Auto Ingress Contact



DESIGN
MANUFACTURE
SALES
SERVICE



ECO Series



ECO 42B



Applications

Double Leaf Sliding Door System

- Entrance and internal door applications
- Ideal upgrade for retail outlets
- Office interiors
- Restaurants, Coffee Shop
- Small super stores
- Saloon, Spa, Clinics, Pharmacy etc.

Technical Specification Data

Function / Parameter / Criteria	ECO 42B
General Features	
Track overall dimensions in mm (Height x Depth)	155 x 110
Max clear opening width in mm	2000
Max Recommended height in mm	2400
Max track length in mm	4200
Max weight per leaf (in Kgs)	85
Power supply (Input voltage)	220V ± 10%
Motor Power	70W
Standard Door Type (G-Glass, T-Timber, M-Metal, U- UPVC)	G, T, M, U
Recommended fixing/mounting (W-Wall, MS, F-Facade)	W, MS, F
EM Lock	Not included, optional
User Selection Modes	Auto/Open/Close
Max Recommended glass thickness in mm	10/12

Technical Drawings

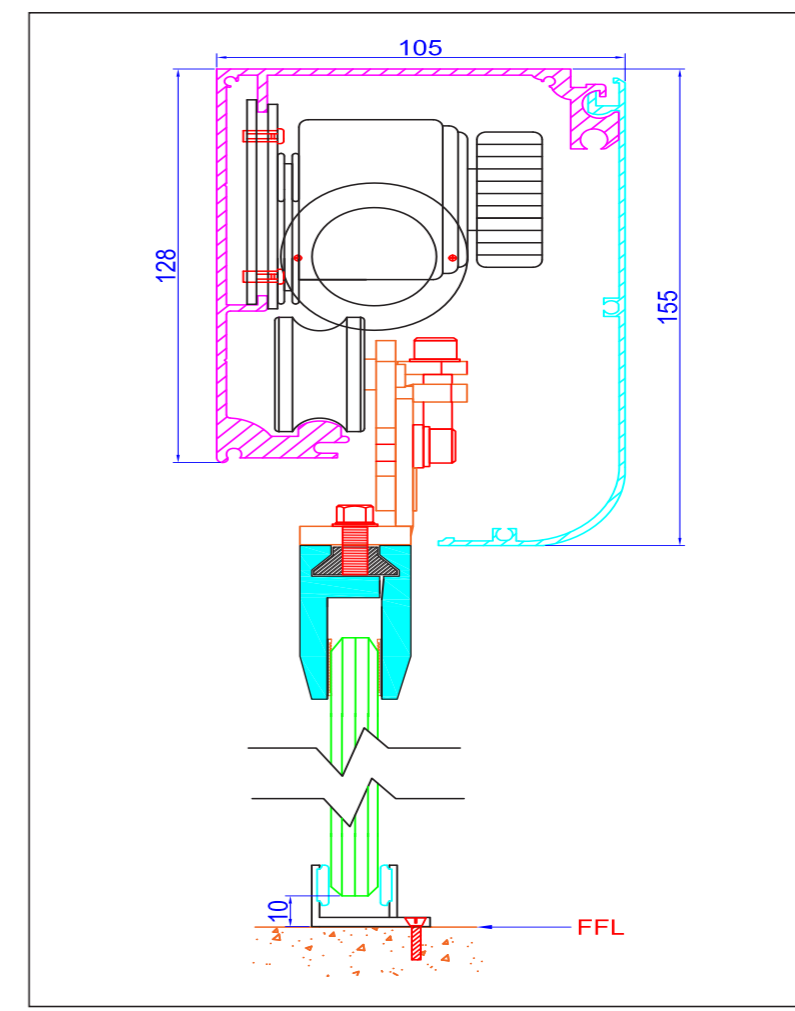

DESIGN
MANUFACTURE
SALES
SERVICE

ECO 25B



Applications

Single Leaf Sliding Door System

- Entrance and internal door applications
- Ideal upgrade for retail outlets
- Office interiors
- Restaurants, Coffee Shop
- Small super stores
- Saloon, Spa, Clinics, Pharmacy etc.

Technical Specification Data

Function / Parameter / Criteria	ECO 25B
General Features	
Track overall dimensions in mm (Height x Depth)	155 x 110
Max clear opening width in mm	1200
Max Recommended height in mm	2400
Max track length in mm	2500
Max weight per leaf (in Kgs)	85
Power supply (Input voltage)	220V ± 10%
Motor Power	70W
Standard Door Type (G-Glass, T-Timber, M-Metal, U- UPVC)	G, T, M, U
Recommended fixing/mounting (W-Wall, MS, F-Facade)	W, MS, F
EM Lock	Not included, optional
User Selection Modes	Auto/Open/Close
Max Recommended glass thickness in mm	10/12

Technical Drawings

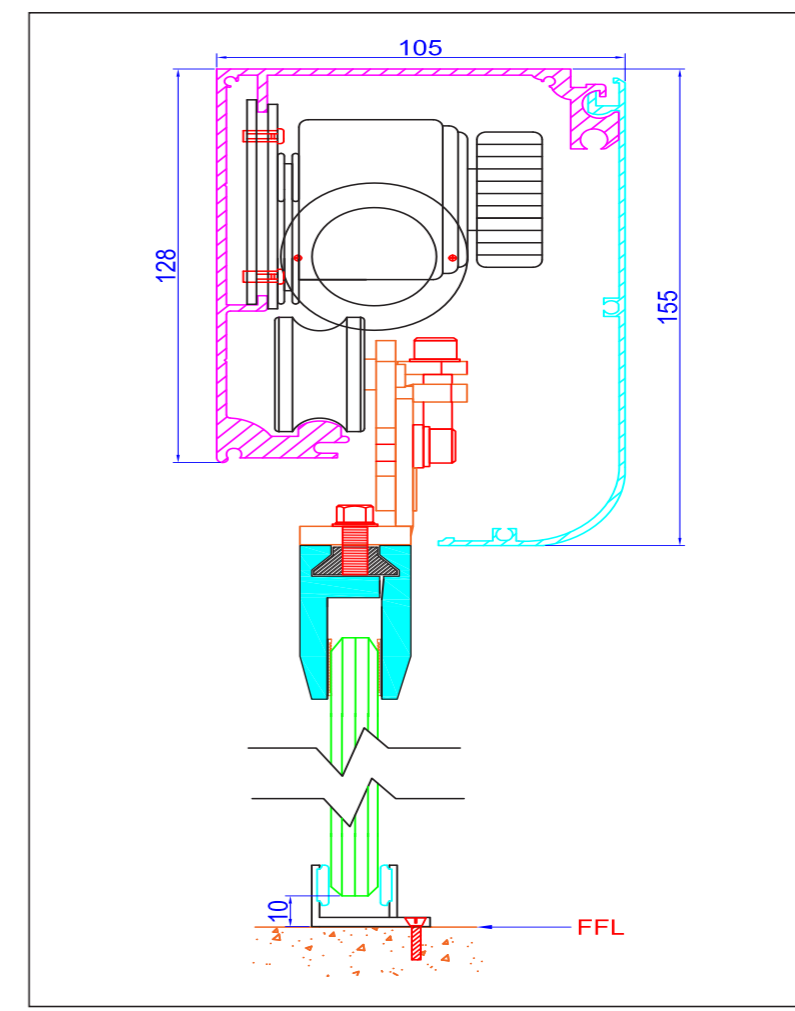

DESIGN
MANUFACTURE
SALES
SERVICE

ECO Lite

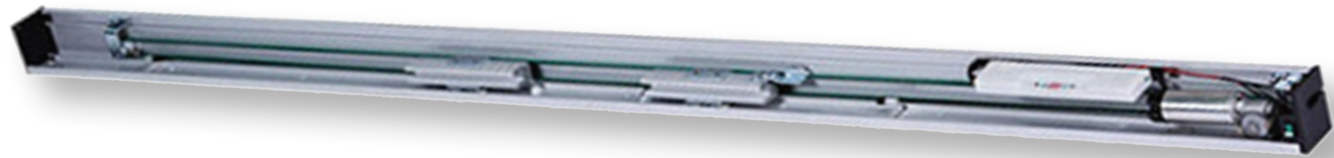

Applications

Single Leaf Sliding Door System

- Internal door applications
- Residential interiors
- Patio doors
- Wardrobe doors
- Office interiors
- Cash / Ticket counters
- Drive-in food outlet service windows
- Pharmacy service windows

Technical Specification Data

Function / Parameter / Criteria	ECO Lite
General Features	
Track overall dimensions in mm (Height x Depth)	68 x 80
Max clear opening width in mm	1000
Max Recommended height in mm	2200
Max track length in mm	2200
Max weight per leaf (in Kgs)	50
Power supply (Input voltage)	220V ± 10%
Motor Power	55W
Standard Door Type (G-Glass, T-Timber, M-Metal, U- UPVC)	Glass
Recommended fixing/mounting (W-Wall, MS, C-Ceiling)	W, MS, C
EM Lock	Not included, optional
User Selection Modes	Auto/Manual/Open/Close/Pet
Max Recommended glass thickness in mm	8/10

Technical Drawings

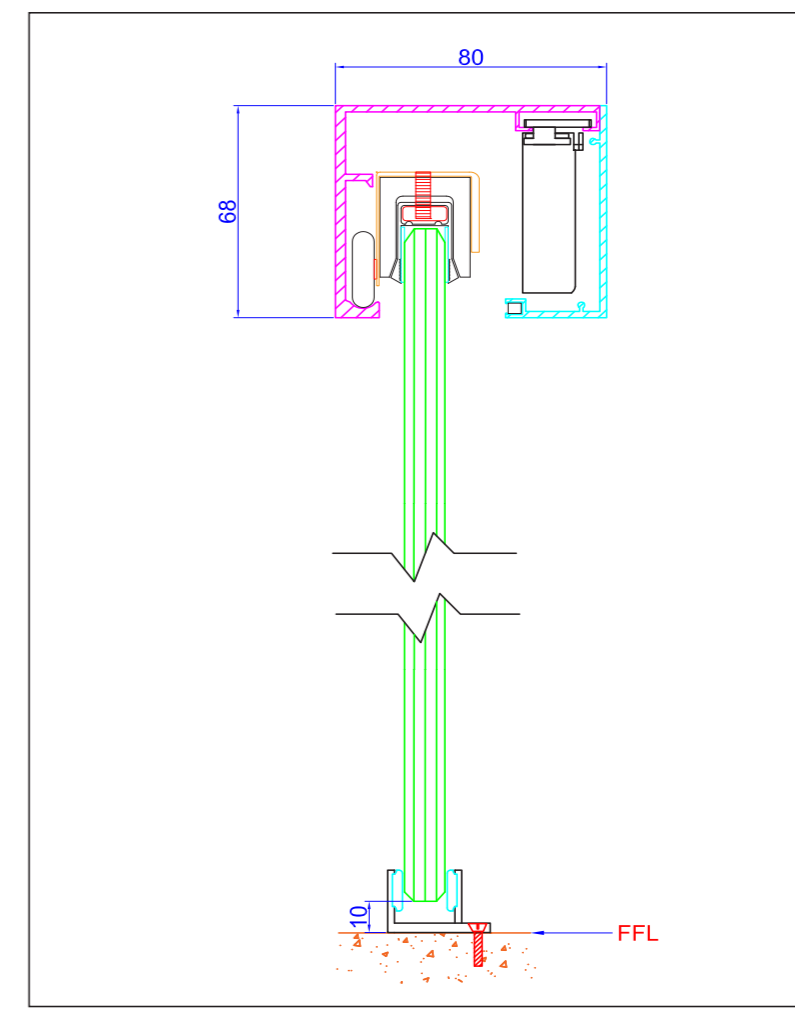

DESIGN
MANUFACTURE
SALES
SERVICE

ECO Sleek



Applications

Single Leaf Sliding Door System

- Suitable for UPVC doors and windows
- Commercial interiors
- Residential interiors
- Patio doors
- Balcony doors

Technical Specification Data

Function / Parameter / Criteria	ECO Sleek
General Features	
Track overall dimensions in mm (Height x Depth)	72 x 63
Max clear opening width in mm	1000
Max Recommended height in mm	2100
Max track length in mm	2200
Max weight per leaf (in Kgs)	No suspended weight
Power supply (Input voltage)	220V ± 10%
Motor Power	55W
Standard Door Type (G-Glass, T-Timber, M-Metal, U-UPVC)	UPVC
Recommended fixing/mounting (W-Wall, U-UPVC Frame)	W, U
EM Lock	Not applicable
User Selection Modes	Auto/Manual/Open/Close/Pet
Max Recommended glass thickness in mm	Remote unit

Technical Drawings

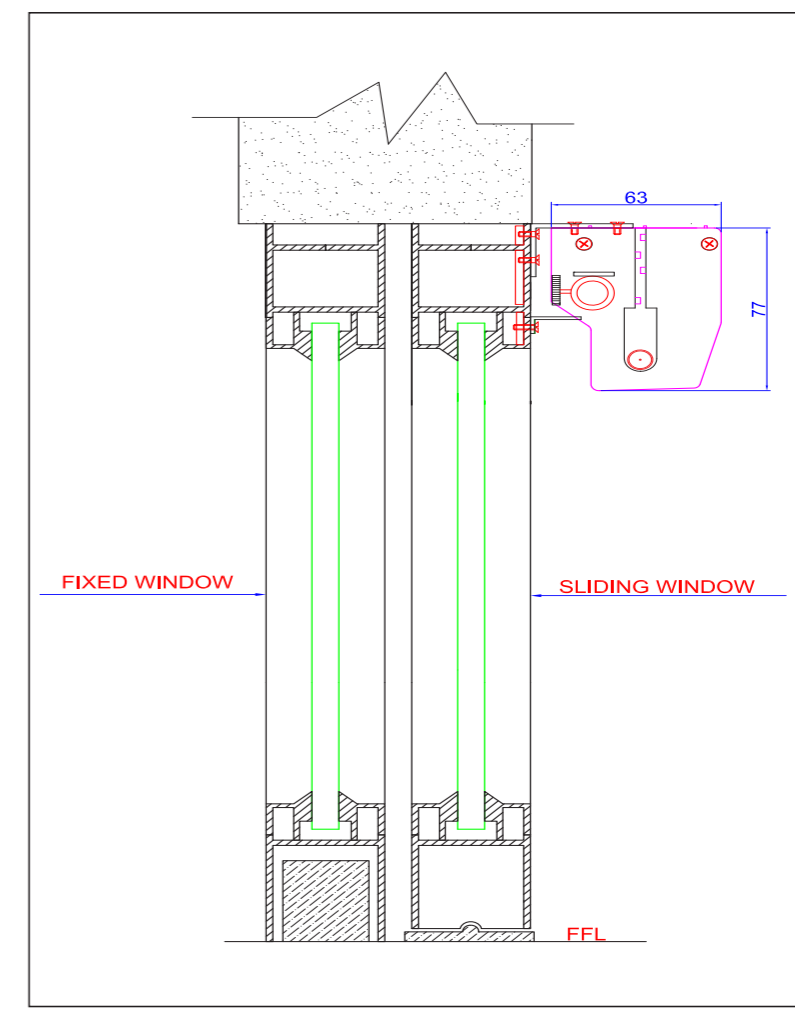

DESIGN
MANUFACTURE
SALES
SERVICE

ECO TOP



Technical Specification Data

Function / Parameter / Criteria	ECO Top
General Features	
Track overall dimensions in mm (Height x Depth x Length)	80 x 115 x 515
Max door width in mm	1200
Max Recommended height in mm	2400
Max weight per leaf (in Kgs)	120Kgs
Minimum opening achievable in mm	450
Power supply (Input voltage) #	220V ± 10%
Motor Power	70W
Standard Door Type: Standard Door Type (G-Glass, T-Timber, M-Metal, U-UPVC) Note: Channel for frameless Glass available	G, T, M, U
Recommended fixing/mounting (W-Wall, MS)	W, MS
Electric Lock	Not included, optional
User Selection Modes	Auto/Open/Close

Technical Drawings

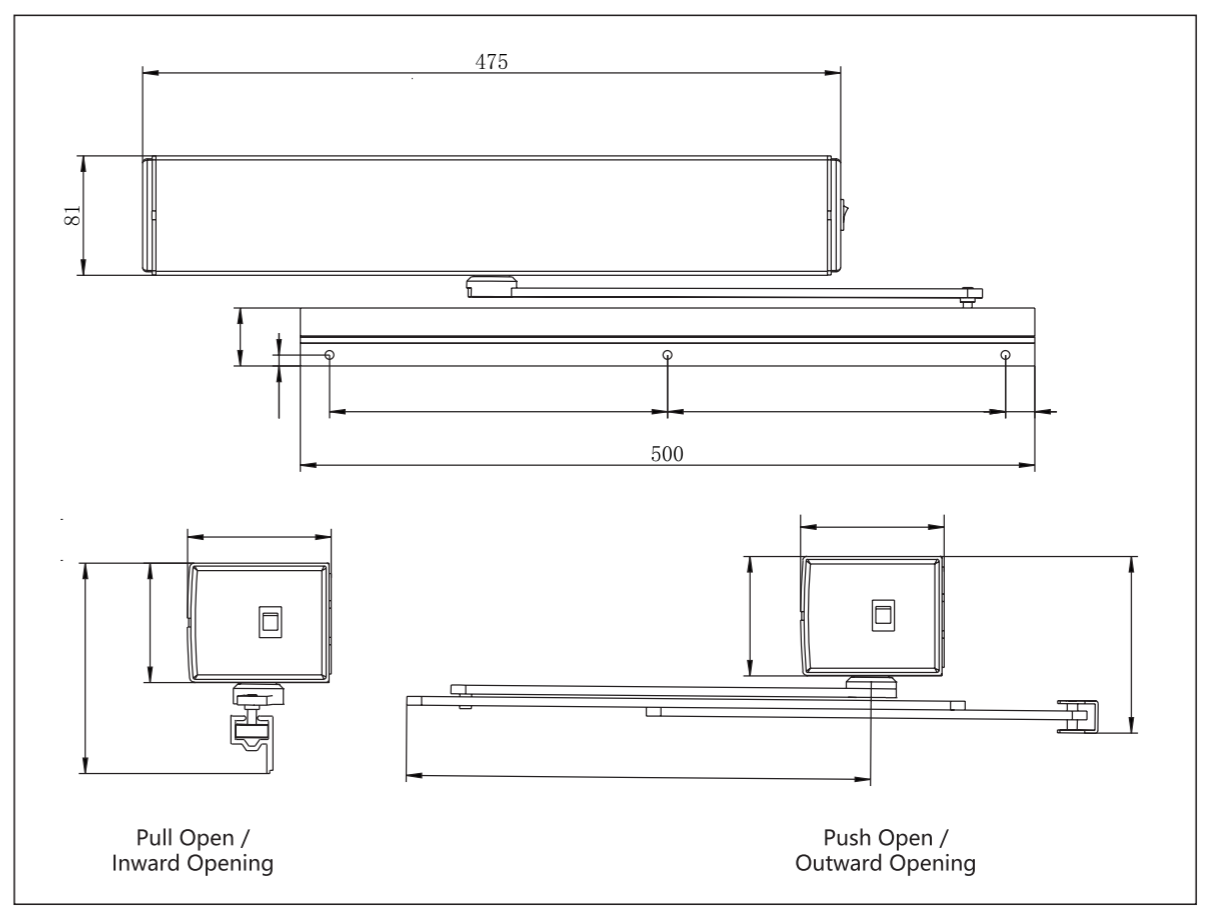

Applications



- Entrance and internal door applications
- Retrofit for existing manual swing doors
- Office interiors
- Residential interiors
- Small super stores

DESIGN ▲
MANUFACTURE ▲
SALES ▲
SERVICE ▲

